

AUTOCLEAR 4626

Portable, Compact Parcel X-ray for Bombs, Weapons & Contraband



Lower profile, array-on-top sharpens threat details and better fills the screen.

AUTOCLEAR is the leading world-wide producer of advanced, fast, reliable, X-ray, Weapons and Trace Detection screening systems, easily integrated or leased. Visit us at www.autoclearus.com. Ask about our mobile, cargo dual-viewer backscatter systems.

The AUTOCLEAR® 4626 (46.0 cm wide x 26.0 cm high, 18.1" wide x 10.2" high opening) is compact, lightweight and ergonomic for briefcases, purses, cameras, laptops, backpacks, shoes, coats, mailbags, bins and parcels. Ideal for:

**Schools • Courthouses
Correctional • Corporate
Mailrooms Embassies • Jails
Government Buildings
Special Events • Airports
Military • Banks • Police
Nightclubs • Offices
Parcels for Executives**

Features

- Very portable, compact and affordable. Fits narrow halls, spaces, and through any doorway. Ergonomic height and small footprint enhance security.
- Ideal size, penetration and throughput for mail, laptops, shoes, cellphones, coats, binned items, electronics, food, liquids, handbags, and cameras.
- Advanced, bright digital image. Folded array rapidly images full mailbags, long packages (posters, drawings) and taller items. Unlike high-dose analog, door-based fluoroscopes with dull, monochrome, indirect views, the 4626 is fully film-safe and will not cut off corners.
- Features Pentium 4, 17" monitor, RealClear®, autoScale®, autoDensAlert®, autoOutline®, autoSensing®, autoCal®, 64X Smart Zoom, Lighten, Help, DensityScan, and Low Density Stripping, among other features.
- 90kV, 10-11mm penetration eliminates hand searches. Twice the penetration available in less portable systems costing more.
- Multi-Energy Color with Organic/Inorganic Stripping is popular. Half the radiation dose to parcels and contains with lower energy consumption. TIP, Training and Image Archiving autoSaves® images to DVD, CD or USB flash drive. autoMatalert® option highlights organic threat items.
- autoTracking® unique guided conveyor belt system never needs adjustment, lowering operating costs.
- Full autoSensing® eliminates use of troublesome photosensing systems or footpad switches. Assures 100% screening of thin blades or plastic in magazines or overnight envelopes, or bag already in tunnel at start-up.
- Interactive training and highly responsive local service. Engineered, made and rigorously tested in North America to the highest ISO 9000 and regulatory standards.

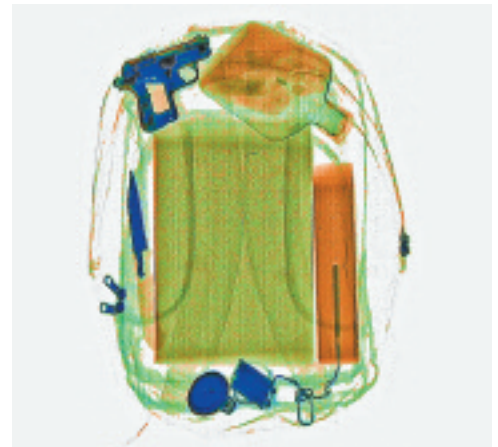

RealClear® reveals components of a gun, knife, narcotics in bottle, and bomb in real time, without lags and delays. autoScale® displays contents at Pentium 4 resolution automatically and without distortion.



User-friendly, ergonomic and fully-featured operator control panel.

70 years leading innovation in checkpoint detection & support

Model 4626 Very Compact X-ray Specifications

Overall Dimensions: Inspection Capabilities

Tunnel Size:	109.1 cm (43.0") L x 58.4 cm (23.0") W x 103.6 cm (40.8") H
Material Penetration:	18.1" wide (46 cm) 10.2" high (26 cm) L-shaped detector for 100% package screening.
Contrast Sensitivity:	10-11 mm (0.39-0.43") steel, twice the penetration in its class.
Resolution:	Over 2 million color tones standard.
Processing:	40 AWG wire. 32-bit adaptive image processing with minimum 128 Mbytes memory; 800 MHz, 2.4 GHz or higher processor.
Conveyor Speed:	48 feet per minute; 24 cm per second. Fully reversible.
Pulling Weight:	100 kg (220 lbs) standard; 200 kg (440 lbs) option
autoTracking®:	Belt guaranteed to autoTrack for life.
Film Safety:	Guaranteed for high-speed films up to ISO 1600 (33 DIN).
*Full autoSensing® without troublesome photosensors, moving parts, or footpad.	Reduces downtime and assures all magazines, envelopes or items are scanned, no matter how thin, or of bag already in tunnel at start-up. Enhances radiation safety.

X-ray Generator

X-ray tube head:	Self-contained
High voltage rating:	90 kV standard
Duty cycle:	100% with sealed oil bath cooling
Beam orientation:	Diagonal (80° beam divergence)
Dose rate per exam:	0.1 mR. Lower doses available.

X-ray Detectors

Surface mounted, multilayer, fully integrated, high frequency, solid state detectors using high speed processors, and Pentium 4 image processing with Single Energy or optional Multi-Energy (M) Color.

Video

Standard with color 17" LCD flat screen monitor. High resolution, flicker-free, low rad., low energy monitor, 1280 x 1024 video card. Single energy color is based on object density. Multi-Energy option available with second monitor, CRT(s) or larger monitor(s), displays organics in orange and inorganics in blue, both overlapping in green and very dense objects in black, and includes Organic and Inorganic Stripping.

Standard Features

- RealClear®
- autoDensAlert®
- autoTracking®
- autoSensing®
- autoOutline®
- autoScale®
- autoCal®
- 1.5, 2, 2.5, 3, 3.5 4,6, 8, 16, 32 and 64X smart zoom
- Dark & Light enhance
- DensityScan
- Color; Reverse B/W
- High/Low Density & Stripping
- High density
- Integrated undercarriage
- Brushed alum. tunnel extensions
- Helpscreens
- Fast (25 second) initial warm-up
- Full-sized, friendly, robust keyboard
- Reversible direction & image
- Non-marring castors

Options

- Multi-Energy (M) color material identification with organic and inorganic stripping
- Image Archiving with autoSave® to DVD, CD, or USB Flash
- Threat Image Projection (TIP)
- autoMatalert®
- Tropical Humidity Kit
- Loading or exit trays or rollerbeds
- CRT, dual or larger monitors
- Locking metal keypad cover
- Clear Lexan tunnel extensions
- CE marking or UK approved
- kV, mA meter or item counter
- Power conditioner, or UPS
- Longer Canadian or UK versions
- Variable height keypad mount
- Locking monitor(s) hood
- Remote operation; printer or archiving cables
- Built-in Training
- Rental or leases
- autoNet
- TipNet

Physical Details

Dimensions:	See drawing
Weight:	410 lbs (186 kg) (including undercarriage) 560 lbs (254 kg) crated
Construction:	Unibody heavy gauge epoxy painted steel construction with stainless steel and aluminum trim and accessories. Corrosion-resistant command center keyboard.
Environmental Conditions:	Temperature range: 32° - 104°F, (0° - 40°C) • Humidity 20% - 95%, non-condensing. Storage to 65°C (149°F)
Electrical Power Requirements:	Consumption: < 0.7 kVA 100, 120, 230 volts AC + 10%, < 7 amps. 200, 220, 230, 240, 250 volts AC ± 10%, < 3.5 amps. All at 50 or 60 Hz.

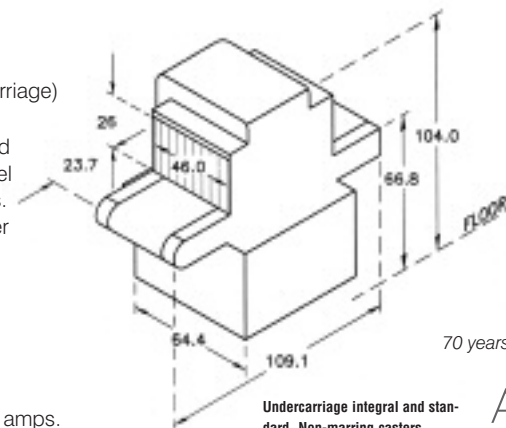

Undercarriage integral and standard. Non-marring casters

Dimensions are in centimeters
Note: Non-marring casters

ISO 9001-2000 Certified

70 years leading innovation in checkpoint detection & support

