

# AUTOCLEAR 100100T

## 1.0m x 1.0m Checked Bag X-ray For Explosives, Weapons & Narcotics



RealClear® reveals narcotics in a bottle and bomb components in real time, without lags and delays. autoScale® displays contents at Pentium 4 resolution automatically and without distortion.



Available operator table and dual or LCD monitors (one 17" CRT is the normal configuration).

Control Screening is the leading worldwide producer of fast, reliable and sophisticated X-ray, Metal and Trace Detection screening systems.

Ask about our mobile and cargo systems. Our advanced systems and options are often integrated, leased or rented.

The AUTOCLEAR® 100100T (featuring a 1.0 m wide x 1.0 m high or 39.4" wide x 39.4" high tunnel opening), is a heavy-duty, conveyORIZED, X-ray scanner designed for screening cargo and large checked luggage, detecting concealed weapons, explosives, narcotics, currency, contraband or manifest fraud at:

**Airports • Seaports • Courts  
Customs • Corporate Facilities  
Government Buildings  
Checkpoints • Loading Docks  
Mailrooms  
Corrections Facilities  
Nuclear • Access Control  
Special Events • Hospitals  
Rail or Bus Stations  
Police Stations • Military Bases**

### Features

Low to the floor, heavy-duty, high capacity conveyor with easy changeouts. Rugged construction uses less floor space and head room.

Narrower footprint enhances security. Conveyor end folds up for transport.

Parcel contents are displayed at normal scale, wherever located, automatically and without distortion (autoScale®). RealClear® function reveals components of dense items in realtime without lags or delays.

Features Pentium 4, 17" monitor, Multi-Energy Color with Organic/Inorganic Stripping, RealClear®, autoScale®, autoDensAlert®, autoOutline®, autoSensing®, autoCal®, Lighten, Help, DensityScan, and Low Density Stripping, among other features.

TIP, Training and Image Archiving also available. autoMatalert®, option highlights suspect materials using atomic number and density.

autoTracking® guided conveyor belt system never needs adjustment, lowering operating costs.

autoSensing® eliminates the need for troublesome photosensors or footpad switch. Assures 100% screening of thin blades or plastique in courier envelopes or magazines, or of bag already in tunnel at start-up.

Interactive training and highly responsive local service. Engineered, made and rigorously tested in the USA to ISO 9001 and regulatory standards.

*Celebrating 65 years of excellence in design & support*



Scintrex® • Federal Labs® • CheckGate® • HandWand® • Dynavision® • RealClear®  
U.S. Canada Europe Middle East Latin America Hong Kong Singapore

# Model 100100T X-ray Specifications

**Overall Dimensions:** 317.0 cm (124.8") L x 129.3 cm (50.9") W x 192.9 cm (76.0") H

## Inspection Capabilities

**Tunnel Size:** 39.4" wide (100 cm)  
39.4" wide (100 cm)

**Material Penetration:** 28-29 mm steel

**Contrast Sensitivity:** Over 2 million color tones.

**Resolution:** 40 AWG wire

**Conveyor:** Height: 27 cm or 10.6" off floor.  
Speed: 48.0 feet per minute; 24 cm per second.  
Reversible. Toggles for easy belt changeover.  
Load conveyor extension end folds up for elevator, or ease of transport.

**Pulling Weight:** 150 kg (331 lbs) standard; 403.2 kg (887 lbs) option

**autoTracking®:** Belt guaranteed to autoTrack for life.

**Film Safety:** Guaranteed for high-speed films up to ISO 1600 (33 DIN).

**\*Full autoSensing® without photosensors, moving parts, or footpad.** **Reduces downtime and assures all magazines, envelopes or items are scanned, no matter how thin, or of bag already in tunnel at start-up. Enhances radiation safety.**

## X-ray Generator

**X-ray tube head:** Self-contained, shielded tank High

**voltage rating:** 160 kV, 140 kV Operating Voltage

**Duty cycle:** 100% with sealed oil bath cooling

**Beam orientation:** Diagonal

**Dose rate per exam:** 0.1 mR. Lower doses available.

## X-ray Detectors

Surface-mounted, multilayer, fully integrated, high frequency, solid state detectors using high-speed processors and advanced Pentium 4 signal processing with Multi-Energy.

## Video

Standard with color 17" SVGA monitor. High resolution, flicker-free, .28 dot pitch, low rad. monitor, 1280 x 1024. Multi-Energy color included with available second monitor or flat screen or larger monitor(s). Displays organics in orange and inorganics in blue, both overlapping in green and very dense objects in black.

## Standard Features

- Multi-Energy organic and inorganic color & stripping
- RealClear®
- autoDensAlert®
- autoTracking®
- autoOutline®
- autoScale®
- autoCal®
- Dark & Light enhance
- DensityScan
- Color; Reverse B/W
- High/Low Density & Stripping
- High density
- Help
- Fast (25 second) initial warm-up
- Fully functional, robust, low profile
- Reversible conveyor direction

## Options

- autoMatalert®
- Threat Image Projection (TIP)
- Roller bed or conveyor extensions
- Tropical Humidity Kit
- Power conditioner, or UPS
- CE mark or extra pulling power
- Locking metal keypad cover
- kV, mA meter or item counter
- LCD, dual or larger monitor(s)
- Variable height keypad mount
- Table or locking monitor hood
- Remote; printer or VCR cable
- Built-in training
- Rentals or leases

## Physical Details

**Dimensions:** 124"L x 51" W x 76" H

**Approx. Weight:** 1,593 lbs (722 kg) or 2,195 lbs (996 kg) (crated)

**Construction:** Unibody heavy gauge epoxy-painted steel construction with stainless steel trim and accessories. Non-marring casters, leveling jackscrews, and reinforced forklift pockets. Stainless steel command center keypad mountable on top, or available on side or table.

**Environmental Conditions:** Temperature range: 23° to 131°F, 0°F - 40°F (-20°C - 70°C)  
95% non-condensing.

**Electrical Power Requirements:** Consumption: 110 VAC ± 10% (<6 amps), 200, 220, 240, 250 volts AC ± 10%, 230 VAC ± 10%, 50 Hz ± 3 Hz  
<3 amps. All at 50 or 60 Hz.

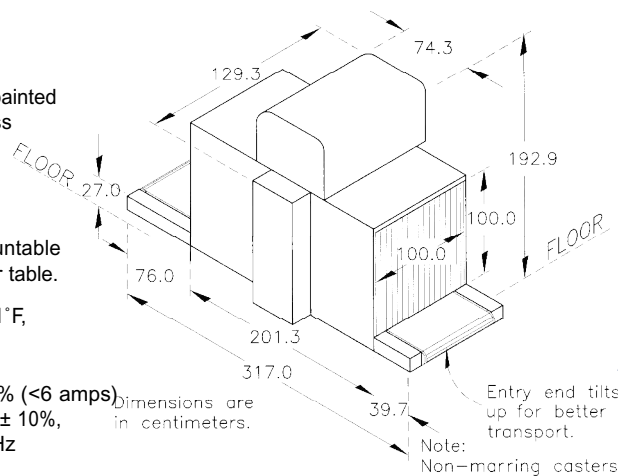

**Provided By:**  
**SECURITY DETECTION**

Specializing in Professional  
Detection Systems **Since 1968**

We Sell and Rent Equipment  
**Internationally**

Visit Us on the Web at:

[www.securitymetaldetectors.com](http://www.securitymetaldetectors.com)

Call Us: TOLL FREE:

1-800-930-3766



**AUTOCLEAR**

Celebrating 65 years of excellence in design & support  
Scintrex® • Federal Labs® • CheckGate®  
HandWand® • Dnnavision® • RealClear®

**Compliance** Complies with the U.S. Federal Aviation Administration Standards "Use of X-Ray Systems" (Federal Standards 14 CFR 108.17 and 14 CFR 129.26; the system conforms to the USBRH Performance Standards for Cabinet X-Ray Systems (21 CFR 1020.40), ISO 9001 compliant. Emergency Stop buttons. Cluster LED X-Ray "ON" indicators for lower maintenance. The electrical system conforms to applicable sections of IEC 348 for Electrical Safety and FCC Docket 20780 for Electromagnetic capability.