

AUTOCLEAR 6040

High Capacity Parcel X-ray for Explosives, Weapons & Narcotics

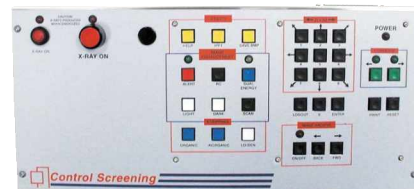

RealClear® reveals components of a gun, knife and bomb in real time, without lags and delays. autoScale® displays contents at Pentium 4 resolution automatically and without distortion.



User-friendly, ergonomic and fully-featured operator control panel.

Control Screening is the leading worldwide producer of fast, reliable and sophisticated X-ray, Metal and Trace Detection screening systems.

Ask about our mobile and cargo systems. Our advanced systems and options are often integrated, leased or rented.

The AUTOCLEAR® 6040 (featuring a 62.0 cm wide x 42.0 cm high or 24.4" wide x 16.5" high tunnel opening) is a high capacity, high penetration, heavy-duty, conveyORIZED X-ray scanner designed to inspect carry-on bags, briefcases, mail trays and parcels. Ideal for use at:

Airports • Seaports • Courts
Customs • Corporate Facilities
Government Buildings • Postal
Checkpoints • Loading Docks
Mailrooms • Corrections Facilities
Nuclear • Access Control
Special Events • Hospitals
Rail or Bus Stations
Police Stations • Military Bases

Features

autoTracking® guided conveyor belt system never needs adjustment, lowering operating costs.

autoSensing® eliminates the need for troublesome photosensors or footpad switch. Assures 100% screening of thin blades or plastique in magazines or courier envelopes, or of bag already in tunnel at start-up.

Parcel contents are displayed at normal scale, wherever located, automatically and without distortion (autoScale®). RealClear® function reveals components of dense items in realtime without lags or delays.

Narrower footprint enhances security and conveniently fits in elevators, 32" doorways and tight spaces; conveyor end folds up for transport.

Features Pentium 4, 17" monitor, RealClear®, autoScale®, autoDensAlert®, autoOutline®, autoSensing®, autoCal®, 64X Smart Zoom, Lighten, Help, DensityScan, and Low Density Stripping, among other features.

Compact version (above) or airport version with extended conveyor(s).

Multi-Energy Color option with Organic/Inorganic Stripping is popular. TIP, Training and Image Archiving also available. autoMatalert®, option highlights suspect materials using atomic number and density.

Interactive training and highly responsive local service. Engineered, made and rigorously tested in the USA to ISO 9001 and regulatory standards

Celebrating 65 years of excellence in design & support



Model 6040 X-ray Specifications

Overall Dimensions: Inspection Capabilities

	154.6 cm (60.9") L x 80.9 cm (31.9") W x 126.4 cm (49.8") H
Tunnel Size:	24.4" wide (62 cm) 16.5" high (42 cm) L-shaped detector for 100% package screening.
Material Penetration:	28-29 mm steel
Contrast Sensitivity:	Over 2 million color tones standard.
Resolution:	40 AWG wire.
Processing:	24-bit color processing with minimum 128 Mbytes memory; 800 MHz or 2.4 GHz processor.
Conveyor Speed:	48 feet per minute; 24 cm per second. Standard conveyor pictured on reverse. Extended conveyor length, Model 6040E (variable length entrance and exit bed). Fully reversible.
Pulling Weight:	150 kg (331 lbs) (Higher pulling weights available).
autoTracking®:	Belt guaranteed to autoTrack for life.
Film Safety:	Guaranteed for high-speed films up to ISO 1600 (33 DIN).
*Full autoSensing® without photosensors, moving parts, or footpad.	Reduces downtime and assures all magazines, envelopes or items are scanned, no matter how thin, or of bag already in tunnel at start-up. Enhances radiation safety.

X-ray Generator

X-ray tube head:	Self-contained, shielded tank High
voltage rating:	160 kV, 140 kV Operating Voltage
Duty cycle:	100% with sealed oil bath cooling
Beam orientation:	Diagonal
Dose rate per exam:	0.1 mR. Lower doses available.

X-ray Detectors

Surface mounted, multilayer, fully integrated, high frequency, solid state detectors using high speed processors, and Pentium 4 image processing with Single Energy or optional Multi-Energy (M) Color.

Video

Standard with color 17" SVGA monitor. High resolution, flicker-free, .28 dot pitch, low rad. monitor, 1280 x 1024. Single energy color is based on object density. Multi-Energy color option available with available second monitor or flat screen or larger monitor(s), displays organics in orange and inorganics in blue, both overlapping in green and very dense objects in black, and includes Organic and Inorganic Stripping.

Standard Features

- RealClear®
- autoDensAlert®
- autoTracking®
- autoSensing®
- autoOutline®
- autoScale®
- autoCal®
- Dark & Light enhance
- DensityScan
- Color; Reverse B/W
- High/Low Density & Stripping
- High density
- Help
- Fast (25 second) initial warm-up
- Fully functional, robust, low profile
- Reversible conveyor direction

Options

- Multi-Energy organic and inorganic color & stripping
- autoMatalert®
- Threat Image Projection (TIP)
- Rollerbed(s) or conveyor extensions
- Tropical Humidity Kit
- Image Archiving
- CE marking or UK approved
- Power conditioner, or UPS
- Table or locking monitor hood
- Locking metal keypad cover
- kV, mA meter or item counter
- LCD, dual or larger monitor(s)
- Footpad or optical on/off
- Variable height keypad mount
- Clear Lexan conveyor guard
- Remote, printer or VCR cable
- Built-in Training
- Rentals or leases

Physical Details

Dimensions:	See drawing
Weight:	775 lbs (352 kg) or 975 lbs (442 kg) crated
Construction:	Unibody heavy gauge, epoxy painted steel construction with stainless steel and aluminum trim and accessories. Non-marring casters and leveling jackscrews. Stainless steel command center keypad mountable on top, or optional on side or table.

Environmental Conditions:	Temperature range: 23° to 131° F, -5° to 55° C • Humidity 20% - 95%, non-condensing. Storage to 65° C (149° F)
---------------------------	--

Electrical Power Requirements:	Consumption: < .6 kVA, 120 volts AC ± 10% (-6 amps) 200, 220, 240, 250 volts AC ± 10% (<3 amps). All at 50 or 60 Hz.
--------------------------------	--

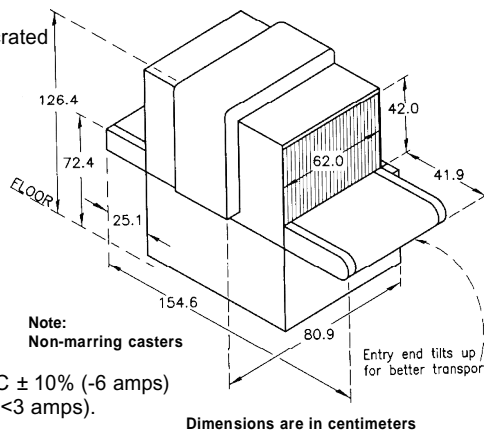

Provided By:
SECURITY DETECTION

Specializing in Professional
Detection Systems **Since 1968**

We Sell and Rent Equipment
Internationally

Visit Us on the Web at:

www.securitymetaldetectors.com

Call Us: TOLL FREE:

1-800-930-3766



AUTOCLEAR

Celebrating 65 years of excellence in design & support
Scintrex® • Federal Labs® • CheckGate®
HandWand® • Dynavision® • RealClear®

Compliance Complies with the U.S. Federal Aviation Administration Standards "Use of X-Ray Systems" (Federal Standards 14 CFR 108.17 and 14 CFR 129.26; the system conforms to the USBRH Performance Standards for Cabinet X-Ray Systems (21 CFR 1020.40), ISO 9001 compliant. Emergency Stop buttons. Cluster LED X-Ray "ON" indicators for lower maintenance. The electrical system conforms to applicable sections of IEC 348 for Electrical Safety and FCC Docket 20780 for Electromagnetic capability.