

Table Top X-Ray Scanner



The all new **MAILGUARD™** letter and small package X-ray security screening system is a compact unit designed for desktop operation, 22.5" wide x 23.5" deep x 30.5" high (57.2cm x 59.7cm x 77.5cm).

The **MAILGUARD™** is ideally suited for the rapid detection of contraband materials in:

Mailrooms • Corporate Offices • Embassies
Prisons • Executives' Residences • Courtrooms

or anywhere that suspect material must be screened and detected.

PRODUCT FEATURES:

- Higher penetrating, more efficient & reliable 90kV X-ray source



X-ray image as seen by viewer

- Extra fine grain resolution, for the sharpest picture.
- Larger overall compartment size - 21" x 18" x 14" (53.3cm x 45.7cm x 35.6cm) - than other models with similar external dimensions and weight
- The **MAILGUARD™** operates with the simplicity of a small office copier. Through advanced technology, the **MAILGUARD™** is only 30.5" (77.5cm) high and weighs less than other machines with similarly sized chambers. This design greatly increases the screen brightness without loss of detail.
- Over 400 items can be examined per hour. Standard envelopes can be examined in batches of 200 to 500 at a time
- The **MAILGUARD™** is completely radiation safe and designed for an office environment. There are no moving parts to maintain. A standard wall socket is all that is required and installation is as easy as plugging it in.

MAILGUARD™ Table Top X-Ray Scanner

ORDERING SPECIFICATIONS:

X-RAY GENERATOR CAPABILITY

Rated 90 kV constant potential peak, high reliability, high frequency X-ray generator.
Current: 1 mA maximum
Cooling: Sealed oil bath, air

COMPARTMENT SIZE

18" (45.7 cm) Wide
21" (53.3 cm) Deep
14" (35.6 cm) High

VIEWING METHOD

Direct view fluoroscopic

FLUOROSCOPIC INSPECTION SCREEN SIZE

17" (43.2 cm) x 17" (43.2 cm)
The full screen area is imaged

RESOLUTION

#36-38 AWG Copper wire

INPUT VOLTAGE AND POWER REQUIREMENTS

110-130 volt or 210-250 volt, (Specify voltage when ordering)
Single phase AC, 50/60 Hertz, under 250 watts

OVERALL SIZE AND WEIGHT

30.5" (77.5 cm) High
22.5" (57.2 cm) Wide
23.5" (59.7 cm) Deep
350 lbs (159 kg)
400 lbs (182 kg) crated

RADIATION SAFETY

Dual Safety interlocks
Panel operating switch
Lockable power switch
Meets or exceeds Federal Standard 21 CFR 1020.40
Meets all applicable International Radiation and CE Marking Standards

CUSTOM OPTIONS

- Transport Cart
- Rental or lease
- Extended Warranty

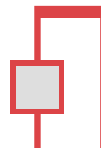
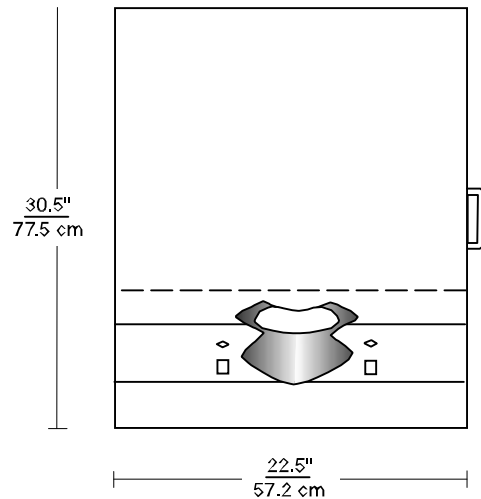
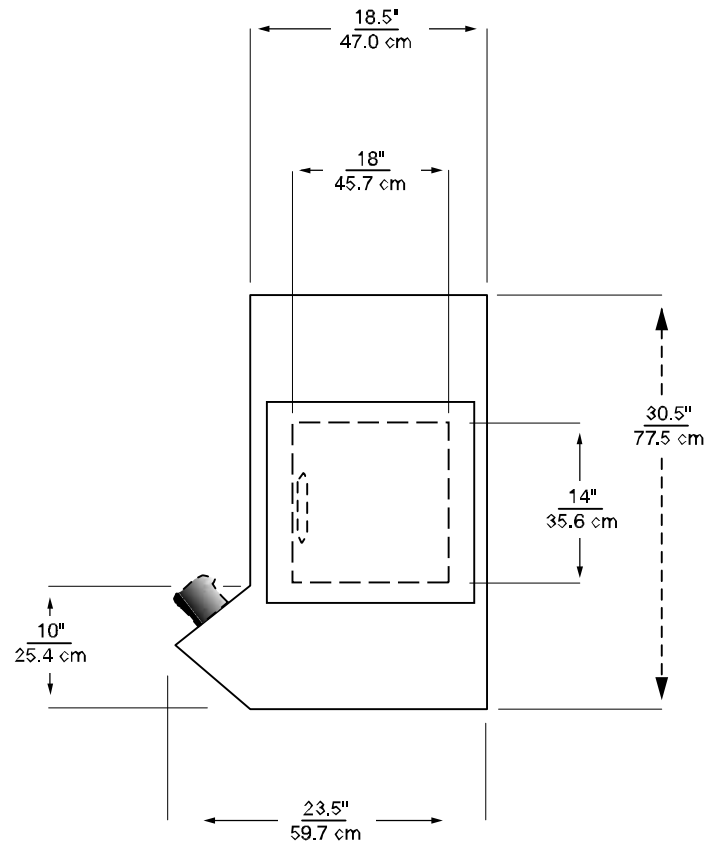

Control Screening

Celebrating 65 years of excellence in design and service

Dynavision® Scintrex® CheckGate® Federal Labs® HandWand®

Provided By:

SECURITY DETECTION

Specializing in Professional Detection Systems **Since 1968**

We Sell and Rent Equipment **Internationally**

Visit Us on the Web at: www.securitymetaldetectors.com

Call Us: TOLL FREE: 1-800-930-3766